

Series  
**VENTS VUT/VUE VB EC**



Air handling units in heat- and sound-insulated casing.  
Air flow up to **690 m<sup>3</sup>/h**.  
Heat recovery efficiency up to **93 %**

**Description**

The air-handling units are the fully featured ventilation units with heat recovery for air filtration, fresh air supply and stale air extraction. During operation the extract air heat is transferred to the supply air stream by the highly efficient plate heat exchanger. The units are designed for energy efficient ventilation of cottages and flats and are compatible with round air ducts (Ø 125, 160 and 200 mm).

**Casing**

Made of high-quality polymer coated steel, internally filled with 20, 25, 30 or 40 mm (depending on the unit model) mineral wool layer for heat and sound insulation.

**Filter**

Supply and exhaust air flows are purified through panel filters with filtering class G4 and F7, respectively. Filters with G4 filtering class are used for supply and exhaust air purification in the **VUT/VUE 250 VB EC** units. F7 filter is available as an option for supply air filtration.

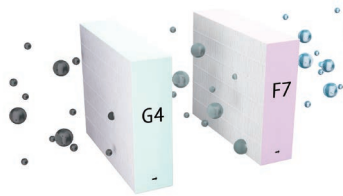

**Fans**

The units are equipped with high-efficient EC motors with an external rotor and a centrifugal impeller with backward curved blades. These state-of-the-art motors are the most advanced solution in energy efficiency today.

EC motors are characterised with high performance and optimum control across the entire speed range. In addition to that, the efficiency of the electronically commutated motor reaches very impressive levels of up to 90 %.

**Heat exchanger**

The **VUT V(B) EC** units are equipped with a counter-flow polystyrene heat exchanger. In the cold season the extract air heat is captured and transferred to the supply air stream which reduces the ventilation-generated heat losses. This can lead to formation of condensate that is collected in a special drain pan and discharged into the sewage system.

In the warm season the ambient air heat is transferred to the exhaust air stream. This allows for a considerable reduction of the supply air temperature which, in turn, reduces the air conditioning load.

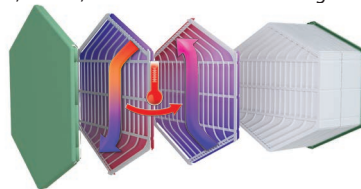

The **VUE V(B) EC** units are equipped with a counterflow enthalpy heat exchanger. In the cold season the extract air heat and moisture are transferred to the supply air stream through the enthalpy heat exchanger reducing the heat losses from ventilation. The ambient air heat and moisture are transferred to the exhaust air stream through the enthalpy heat exchanger in the warm season.

This allows for a considerable reduction of the supply air temperature and humidity which, in turn, reduces the air conditioning load.

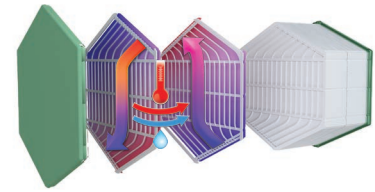

**Bypass**

The **VUT/VUE VB EC** units are equipped with a bypass for summer ventilation (air cooling by the cool air from outside).

**Automation**

The **VUT/VUE V(B) EC A21** units are equipped with a built-in automation system. The A21 controller allows integrating the unit into the Smart Home system or BMS (Building Management Systems). The remote control panel is not included in the delivery set (available separately). To control the unit via Wi-Fi, download the VENTS AHU mobile app.



Google play



Download on the App Store



The **VUT/VUE V(B) EC A14** units have an integrated control system with a wall-mounted control panel A14 with a LED indication.

The **VUT 250 V EC** units are available only with the A14 automation system.

**Freeze protection**

In the **VUT/VUE 160/350/550 VB EC A21** units it is possible to connect a preheater to protect the unit from freezing.

The **VUT 250 VBE EC A21** unit is equipped with a built-in preheater for frost protection.

**Designation key**

Series	Rated air flow [m <sup>3</sup> /h]	Installation features	Casing design	Bypass	Motor type	Service side*	Control
<b>VUT:</b> ventilation with heat recovery <b>VUE:</b> ventilation with energy recovery	160, 250, 300, 350, 550	<b>V:</b> vertical	- by default <b>1:</b> casing modification	_ : without bypass <b>B:</b> with bypass	<b>EC:</b> synchronous electronically commutated motor	<b>L:</b> left <b>R:</b> right	<b>A14</b> <b>A21</b>

\* Only for VUT 250 VB EC L/R

**Control and automation**

Functions	A21	A14
Wired remote control panel	Option (A22) 	A14 
Control via a wired remote LCD control panel	Option (A25) 	-
Wireless remote control panel	Option (A22 Wi-Fi) 	-
BMS	RS-485 Wi-Fi Ethernet MODBUS (RTU, TCP)	-
Vents Cloud Server service	+	-
Control via Wi-Fi using a mobile application	+	-
Freeze protection	+	+
Bypass	Auto + manual	Manual
Week-scheduled operation	+	-
Filter replacement indication	By the filter timer	By the filter timer
	According to filter clogging differential pressure switch readings (only for VUT/VUE 550 VB EC A21)	
Alarm indication	+	+
Speed selection	+	+
Timer	+	-
RH% sensor	Option	Option
CO <sub>2</sub> sensor	Option	Option
VOC sensor	Option	Option
PM2.5 sensor	Option	Option
Boost mode	+	-
Fireplace mode	+	-
Preheater connection	Option (built-in preheater in VUT 250 VBE EC units)	-
Reheater connection	Option	-
Cooler connection	Option	-
Fire alarm sensor	Option	Option
Minimum supply air temperature control	+	-

**Mounting**

The units are designed for wall or floor mounting. Access for maintenance of units and filters is possible from the right and left sides.

**Unit design**

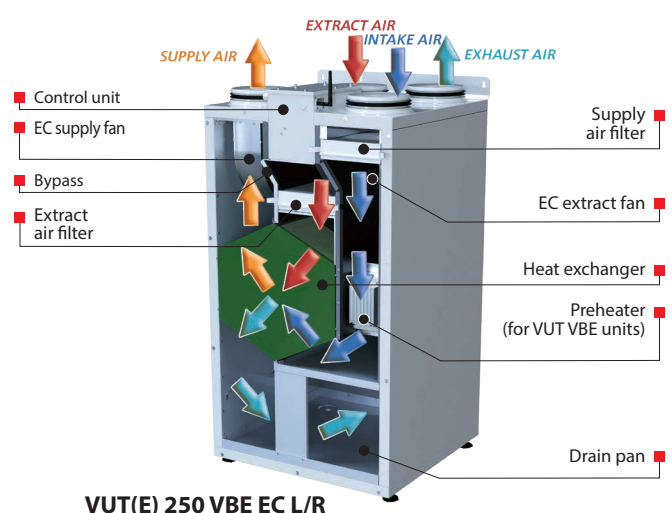
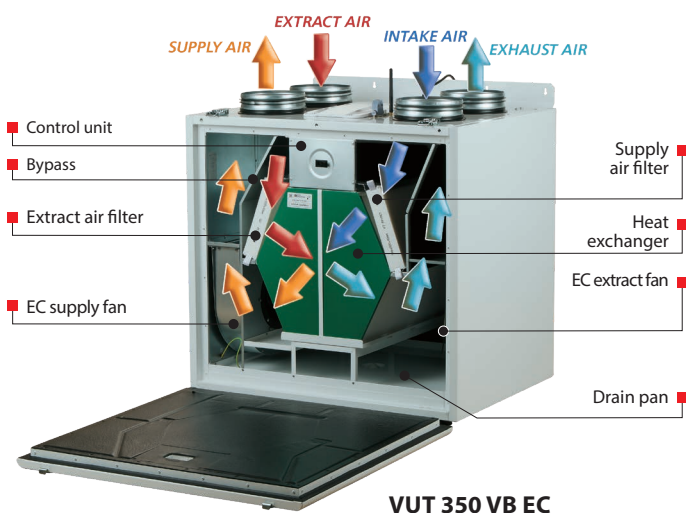

# AIR HANDLING UNITS WITH HEAT RECOVERY

## Technical data

	VUT 160 V EC	VUE 160 V EC	VUT 160 VB EC	VUE 160 VB EC	VUT 160 V1 EC	VUE 160 V1 EC	VUT 160 V1B EC	VUE 160 V1B EC	
Unit voltage [V/50 (60) Hz]					1~230				
Maximum power [W]					57				
Maximum current [A]					0.5				
Maximum air flow [m <sup>3</sup> /h]					200				
RPM [min <sup>-1</sup> ]					3770				
Sound pressure level at 3 m distance [dBA]	24				22				
Transported air temperature [°C]					-25...+40				
Casing material									painting steel
Insulation	20 mm mineral wool				40 mm mineral wool				
Extract filter					G4				
Supply filter					F7 (G4 – option)				
Connected air duct diameter [mm]									Ø125
Weight [kg]	34		36		42		44		
Heat recovery efficiency [%]	85–93	76–92	85–93	76–92	85–93	76–92	85–93	76–92	
Heat exchanger type									counter-flow
Heat exchanger material	polystyrene	enthalpy	polystyrene	enthalpy	polystyrene	enthalpy	polystyrene	enthalpy	
Energy efficiency class for A14, A21	A+	A	A+	A	A+	A	A+	A	

## VENTS VUT/VUE V(B) EC

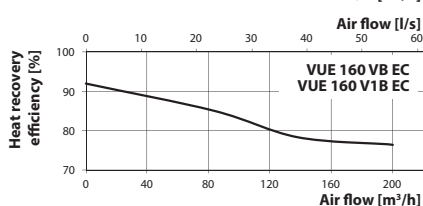
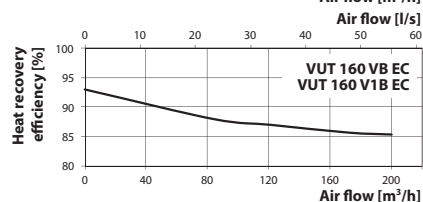
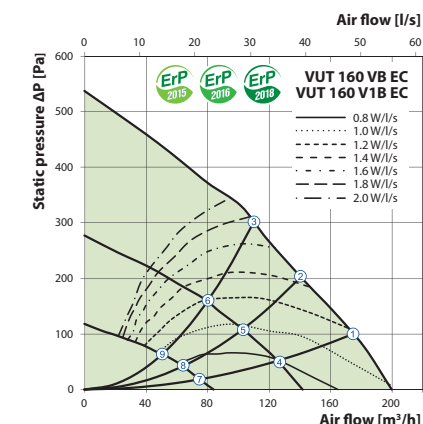

### VUT 160 V EC, VUE 160 V EC, VUT 160 VB EC, VUE 160 VB EC

A-weighted sound power level	Gen.	Octave frequency band [Hz]								LpA, 3 m dBA	LpA, 1 m dBA	
		63	125	250	500	1000	2000	4000	8000			
L <sub>WA</sub> to supply air inlet	dBA	52	28	46	49	41	35	33	36	29		
L <sub>WA</sub> to supply air outlet	dBA	60	32	52	58	47	37	36	41	35		
L <sub>WA</sub> to exhaust air inlet	dBA	51	27	45	49	41	36	32	35	29		
L <sub>WA</sub> to exhaust air outlet	dBA	60	31	50	59	48	36	36	41	32		
L <sub>WA</sub> to environment	dBA	45	25	41	42	34	31	28	27	22	24	34

### VUT 160 V1 EC, VUE 160 V1 EC, VUT 160 V1B EC, VUE 160 V1B EC

A-weighted sound power level	Gen.	Octave frequency band [Hz]								LpA, 3 m dBA	LpA, 1 m dBA	
		63	125	250	500	1000	2000	4000	8000			
L <sub>WA</sub> to supply air inlet	dBA	52	28	46	49	41	35	33	36	29		
L <sub>WA</sub> to supply air outlet	dBA	60	32	52	58	47	37	36	41	35		
L <sub>WA</sub> to exhaust air inlet	dBA	51	27	45	49	41	36	32	35	29		
L <sub>WA</sub> to exhaust air outlet	dBA	60	31	50	59	48	36	36	41	32		
L <sub>WA</sub> to environment	dBA	43	23	39	39	33	29	25	25	20	22	32

**Technical data**

	VUT 250 VB EC L/R	VUE 250 VB EC L/R	VUT 250 VBE EC L/R	VUE 250 VBE EC L/R
Unit voltage [V/50 (60) Hz]	1~230			
Maximum power [W]	177			
Maximum current [A]	1.35			
Electric heater power [W]	-			1400
Electric heater current [A]	-			6.09
Maximum unit power with an electric heater [W]	177			1577
Maximum unit current (with an electric heater) [A]	1.35			7.44
Maximum air flow [m³/h]	370			
RPM [min <sup>-1</sup> ]	2600			
Sound pressure level at 3 m distance [dBA]	47			
Transported air temperature [°C]	-25...+40			
Casing material	painted steel			
Insulation	30 mm mineral wool			
Extract filter	G4			
Supply filter	G4 (F7 – option)			
Connected air duct diameter [mm]	Ø160			
Weight [kg]	66			
Heat recovery efficiency [%]	88–95	78–90	88–95	78–90
Heat exchanger type	counter-flow			
Heat exchanger material	polystyrene	enthalpy	polystyrene	enthalpy
Energy efficiency class for A14, A21	A+	A	A+	A

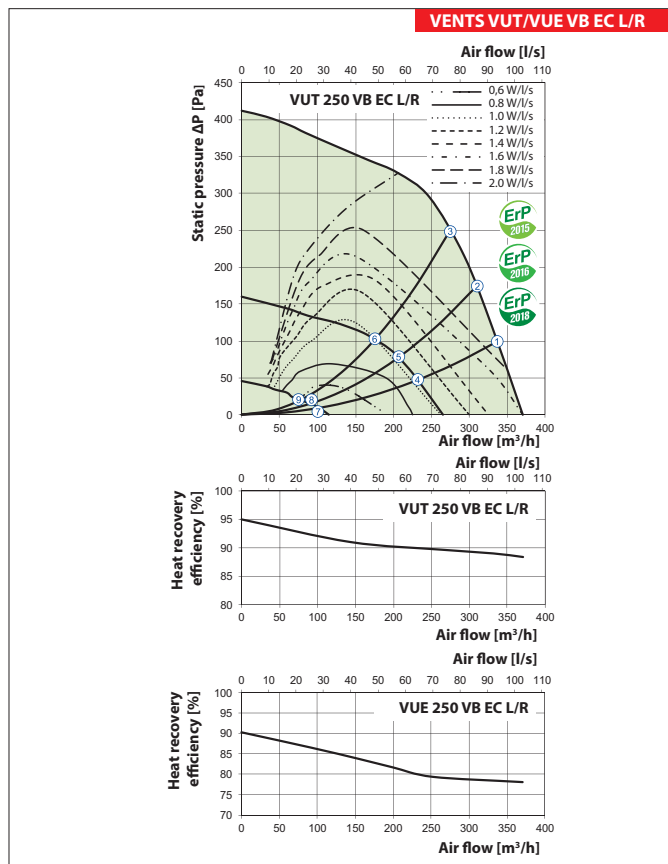



# AIR HANDLING UNITS WITH HEAT RECOVERY

## Technical data

	VUT 350 V1B EC	VUE 350 V1B EC	VUT 350 VB EC	VUE 350 VB EC
Unit voltage [V/50 (60) Hz]	1~230		1~230	
Maximum power [W]	169		178	
Maximum current [A]	1.3		1.4	
Maximum air flow [m <sup>3</sup> /h]	420		450	
RPM [min <sup>-1</sup> ]	3200		3200	
Sound pressure level at 3 m distance [dBA]	28		28	
Transported air temperature [°C]	-25...+40		-25...+40	
Casing material	painted steel		painted steel	
Insulation	40 mm mineral wool		40 mm mineral wool	
Extract filter	G4		G4	
Supply filter	F7 (G4 – option)		F7 (G4 – option)	
Connected air duct diameter [mm]	Ø160		Ø160	
Weight [kg]	57		64	
Heat recovery efficiency [%]	85–92	74–91	85–92	73–91
Heat exchanger type	counter-flow		counter-flow	
Heat exchanger material	polystyrene	enthalpy	polystyrene	enthalpy
Energy efficiency class for A14, A21	A+	A	A+	A

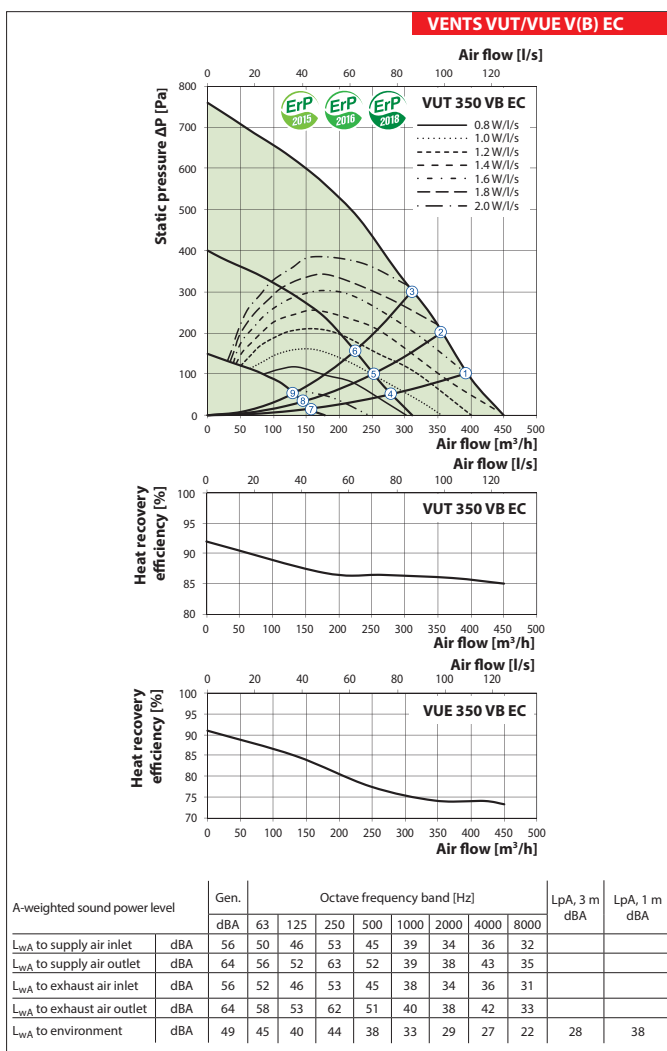
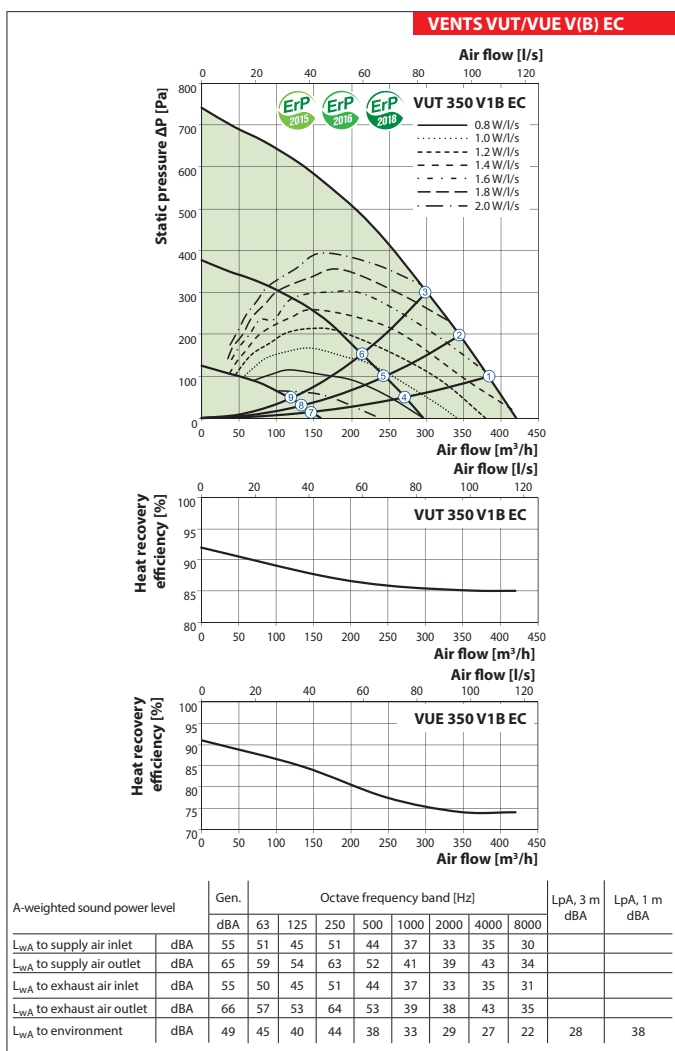

**Technical data**

	VUT 550 VB EC	VUE 550 VB EC
Unit voltage [V/50 (60) Hz]	1~230	
Maximum power [W]	337	
Maximum current [A]	2.4	
Maximum air flow [m³/h]	690	
RPM [min⁻¹]	2860	
Sound pressure level at 3 m distance [dBA]	26	
Transported air temperature [°C]	-25...+40	
Casing material	painted steel	
Insulation	40 mm mineral wool	
Extract filter	G4	
Supply filter	F7 (G4 – option)	
Connected air duct diameter [mm]	Ø200	
Weight [kg]	82	
Heat recovery efficiency [%]	84–92	73–91
Heat exchanger type	counter-flow	
Heat exchanger material	polystyrene	enthalpy
Energy efficiency class for A14, A21	A+	A

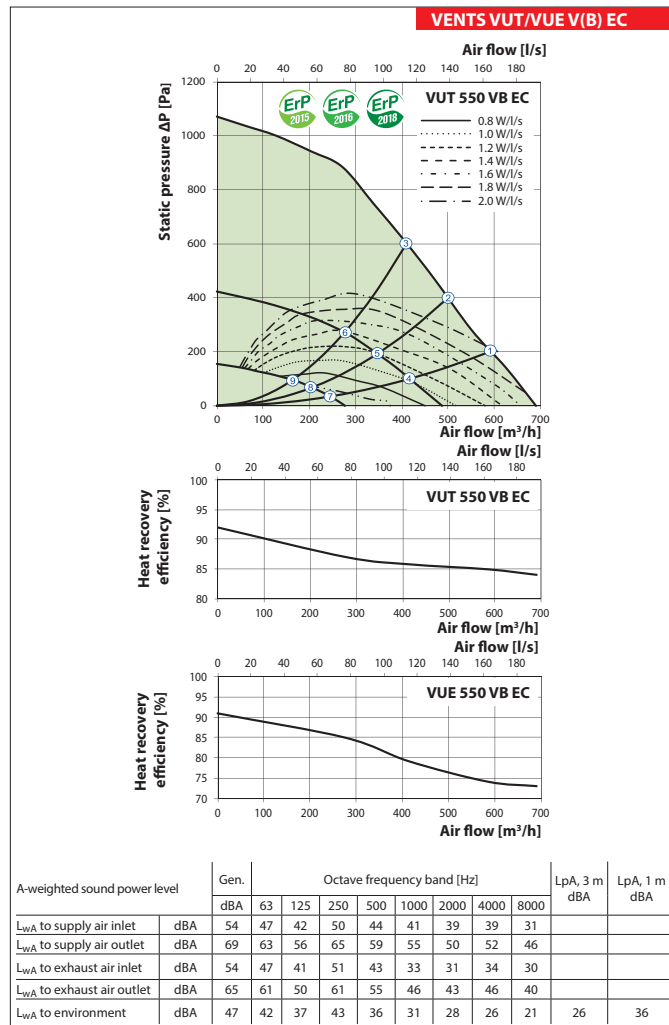

## AIR HANDLING UNITS WITH HEAT RECOVERY

### Technical data

VUT 350 VB EC				VUT 550 VB EC			
Outlet spigot configuration	Air flow [l/s]	Specific power input [W/l/s]	Heat exchange efficiency [%]	Outlet spigot configuration	Air flow [l/s]	Specific power input [W/l/s]	Heat exchange efficiency [%]
Kitchen + 1 additional room with high level of humidity	21	0.71	88	Kitchen + 1 additional room with high level of humidity	21	0.71	87
Kitchen + 2 additional rooms with high levels of humidity	29	0.64	88	Kitchen + 2 additional rooms with high levels of humidity	29	0.63	88
Kitchen + 3 additional rooms with high levels of humidity	37	0.68	87	Kitchen + 3 additional rooms with high levels of humidity	37	0.63	88
Kitchen + 4 additional rooms with high levels of humidity	45	0.76	86	Kitchen + 4 additional rooms with high levels of humidity	45	0.72	88
Kitchen + 5 additional rooms with high levels of humidity	53	0.86	86	Kitchen + 5 additional rooms with high levels of humidity	53	0.84	88
Kitchen + 6 additional rooms with high levels of humidity	61	1.07	85	Kitchen + 6 additional rooms with high levels of humidity	61	0.98	87
Kitchen + 7 additional rooms with high levels of humidity	69	1.26	85	Kitchen + 7 additional rooms with high levels of humidity	69	1.16	87

### Calculation of air temperature at heat exchanger outlet:

$$t = t_{\text{outd}} + k_{\text{hr}} * (t_{\text{extr}} - t_{\text{outd}}) / 100,$$

where

$t_{\text{outd}}$  is outdoor air temperature [°C]

$t_{\text{extr}}$  is extract air temperature [°C]

$k_{\text{hr}}$  is heat exchanger efficiency (according to the diagram) [%]

Point	Power [W]				
	VUT 160 V EC VUT 160 VB EC VUT 160 V1 EC VUT 160 V1B EC VUE 160 V EC VUE 160 VB EC VUE 160 V1 EC VUE 160 V1B EC	VUT 250 VB EC L/R VUE 250 VB EC L/R	VUT 350 V1B EC VUE 350 V1B EC	VUT 350 VB EC VUE 350 VB EC	VUT 550 VB EC VUE 550 VB EC
1	57	177	168	177	337
2	56	173	166	175	337
3	54	140	162	170	337
4	28	58	65	71	118
5	27	54	64	71	113
6	26	44	62	69	107
7	14	14	18	21	34
8	13	13	17	21	66
9	13	12	17	21	32

Point	Sound pressure level at 3 m distance [dBA]			
	VUT 160 V EC VUT 160 VB EC VUT 160 V1 EC VUT 160 V1B EC VUE 160 V EC VUE 160 VB EC VUE 160 V1 EC VUE 160 V1B EC	VUT 350 V1B EC VUE 350 V1B EC	VUT 350 VB EC VUE 350 VB EC	VUT 550 VB EC VUE 550 VB EC
1	24 (34)	28 (38)	28 (38)	26 (36)
2	23 (33)	27 (37)	27 (37)	26 (36)
3	23 (33)	27 (37)	27 (37)	25 (35)
4	20 (30)	23 (33)	23 (33)	24 (34)
5	20 (30)	22 (32)	22 (32)	24 (34)
6	20 (30)	22 (32)	22 (32)	22 (32)
7	13 (23)	15 (25)	15 (25)	15 (25)
8	13 (23)	14 (24)	14 (24)	14 (24)
9	13 (23)	14 (24)	14 (24)	13 (23)





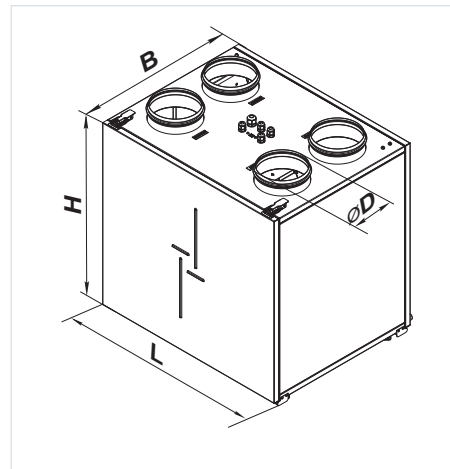



#### Overall dimensions









Model	Dimensions [mm]			
	Ø D	B	H	L
VUT/VUE 160 V EC	125	330	550	600
VUT/VUE 160 V1 EC	125	370	590	640
VUT/VUE 160 VB EC	125	330	580	600
VUT/VUE 160 V1B EC	125	370	620	640
VUT/VUE 250 VB EC L/R	160	560	970	560
VUT/VUE 350 VB EC	160	583	675	730
VUT/VUE 350 V1B EC	160	470	675	730
VUT/VUE 550 VB EC	200	720	675	823



## AIR HANDLING UNITS WITH HEAT RECOVERY

### Accessories for air handling units

Model	G3 panel filter	G4 panel filter	F7 panel filter	LCD control panel	Control panel	Control panel with Wi-Fi	Indoor humidity sensor	CO <sub>2</sub> sensor with indication	CO <sub>2</sub> sensor	Humidity sensor
										
VUT 160 V EC A14				-	-	-				
VUE 160 V EC A14				-	-	-				
VUT 160 VB EC A21				A25	A22	A22 Wi-Fi				
VUT 160 VB EC A14				-	-	-				
VUE 160 VB EC A21				A25	A22	A22 Wi-Fi				
VUE 160 VB EC A14	-	SF 285x195x10 G4	SF 285x195x10 F7	-	-	-				
VUT 160 V1 EC A14				-	-	-				
VUE 160 V1 EC A14				-	-	-				
VUT 160 V1B EC A21				A25	A22	A22 Wi-Fi				
VUT 160 V1B EC A14				-	-	-				
VUE 160 V1B EC A21				A25	A22	A22 Wi-Fi				
VUE 160 V1B EC A14				-	-	-				
VUT 250 VB EC A21				A25	A22	A22 Wi-Fi				
VUT 250 VB EC A14	-	SF 340x170x48 G4	SF 340x170x48 F7	-	-	-	HV2	CO2-1	CO2-2	HR-S
VUE 250 VB EC A21				A25	A22	A22 Wi-Fi				
VUE 250 VB EC A14				-	-	-				
VUT 350 V1B EC A21				A25	A22	A22 Wi-Fi				
VUT 350 V1B EC A14	-	SF 384x196x40 G4	SF 384x196x40 F7	-	-	-				
VUE 350 V1B EC A21				A25	A22	A22 Wi-Fi				
VUE 350 V1B EC A14				-	-	-				
VUT 350 VB EC A21				A25	A22	A22 Wi-Fi				
VUT 350 VB EC A14		SF 500x196x40 G4	SF 500x196x40 F7	-	-	-				
VUE 350 VB EC A21				A25	A22	A22 Wi-Fi				
VUE 350 VB EC A14				-	-	-				
VUT 550 VB EC A21				A25	A22	A22 Wi-Fi				
VUT 550 VB EC A14	-	SF 630x198x40 G4	SF 630x198x40 F7	-	-	-				
VUE 550 VB EC A21				A25	A22	A22 Wi-Fi				
VUE 550 VB EC A14				-	-	-				

Model	VOC sensor (0-10 V)	CO <sub>2</sub> sensor (0-10 V)	Humidity sensor (0-10 V)	Kitchen hood	Electric preheater	Electric reheater	Hydraulic U-trap	Air damper	Electric actuator	Summer block
										
VUT 160 V EC A14	-	-	-		-	-	SH-32	KRV 125		
VUE 160 V EC A14	-	-	-		-	-	-			VL C6 366/285
VUT 160 VB EC A21	DPWQ30600	DPWQ40200	DPWC11200		NKP-125 A21 V.2	NKD-125 A21 V.2	SH-32			
VUT 160 VB EC A14	-	-	-		-	-	-			
VUE 160 VB EC A21	DPWQ30600	DPWQ40200	DPWC11200		NKP-125 A21 V.2	NKD-125 A21 V.2	-			-
VUE 160 VB EC A14	-	-	-		-	-	-			
VUT 160 V1 EC A14	-	-	-		-	-	SH-32			
VUE 160 V1 EC A14	-	-	-		-	-	-			VL C6 366/285
VUT 160 V1B EC A21	DPWQ30600	DPWQ40200	DPWC11200		NKP-125 A21 V.2	NKD-125 A21 V.2	SH-32			
VUT 160 V1B EC A14	-	-	-		-	-	-			
VUE 160 V1B EC A21	DPWQ30600	DPWQ40200	DPWC11200		NKP-125 A21 V.2	NKD-125 A21 V.2	-			
VUE 160 V1B EC A14	-	-	-		-	-	-			
VUT 250 VB EC A21	DPWQ30600	DPWQ40200	DPWC11200		-	NKD-160 A21 V.2	SH-32			
VUT 250 VB EC A14	-	-	-		-	-	-			
VUE 250 VB EC A21	DPWQ30600	DPWQ40200	DPWC11200	KH-1	-	NKD-160 A21 V.2	-		LF230	
VUE 250 VB EC A14	-	-	-		-	-	-	-		
VUT 350 V1B EC A21	DPWQ30600	DPWQ40200	DPWC11200			NKP-160 A21 V.2	NKD-160 A21 V.2	SH-32		
VUT 350 V1B EC A14	-	-	-			-	-	-		
VUE 350 V1B EC A21	DPWQ30600	DPWQ40200	DPWC11200		NKP-160 A21 V.2	NKD-160 A21 V.2	-	KRV 160		
VUE 350 V1B EC A14	-	-	-		-	-	-			
VUT 350 VB EC A21	DPWQ30600	DPWQ40200	DPWC11200		NKP-160 A21 V.2	NKD-160 A21 V.2	SH-32			
VUT 350 VB EC A14	-	-	-		-	-	-			
VUE 350 VB EC A21	DPWQ30600	DPWQ40200	DPWC11200		NKP-160 A21 V.2	NKD-160 A21 V.2	-			
VUE 350 VB EC A14	-	-	-		-	-	-			
VUT 550 VB EC A21	DPWQ30600	DPWQ40200	DPWC11200		NKP-200 A21 V.2	NKD-200 A21 V.2	SH-32	KRV 200		
VUT 550 VB EC A14	-	-	-		-	-	-			
VUE 550 VB EC A21	DPWQ30600	DPWQ40200	DPWC11200		NKP-200 A21 V.2	NKD-200 A21 V.2	-			
VUE 550 VB EC A14	-	-	-		-	-	-			



Application options

Ventilation hood



Ceiling connector with a disk valve

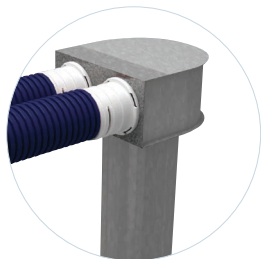

Isovent 150 insulated air duct

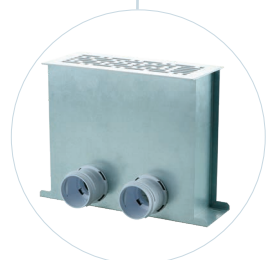
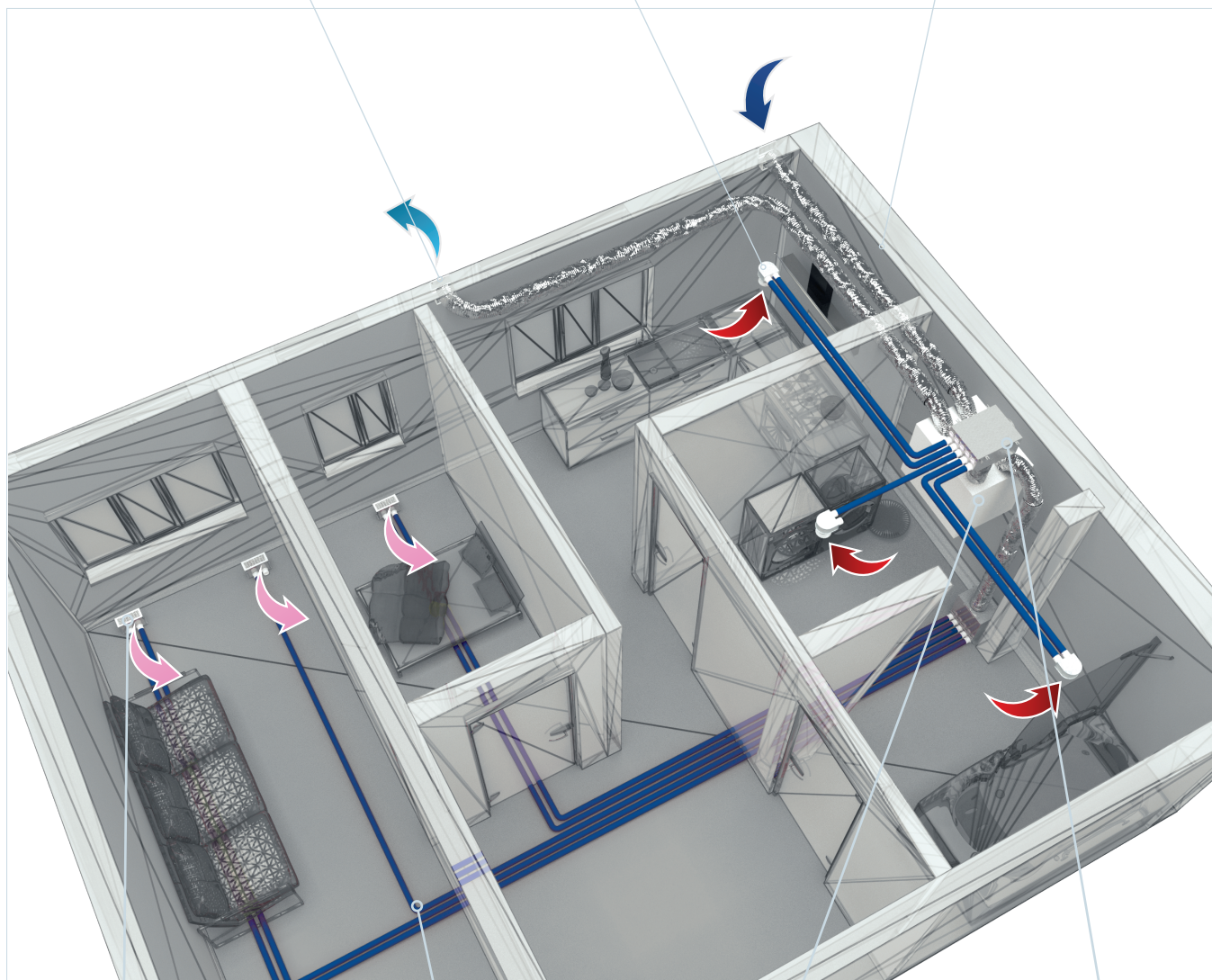

Floor plenum with a grille

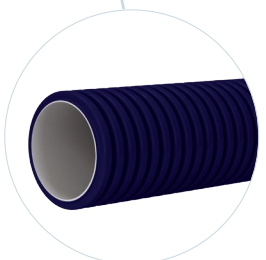

FlexiVent air duct



Air handling unit

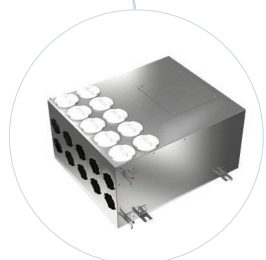

Collector